

H00450 SERIES HEIGHT CONTROL VALVE INSTRUCTIONS

Typical Chassis Configuration

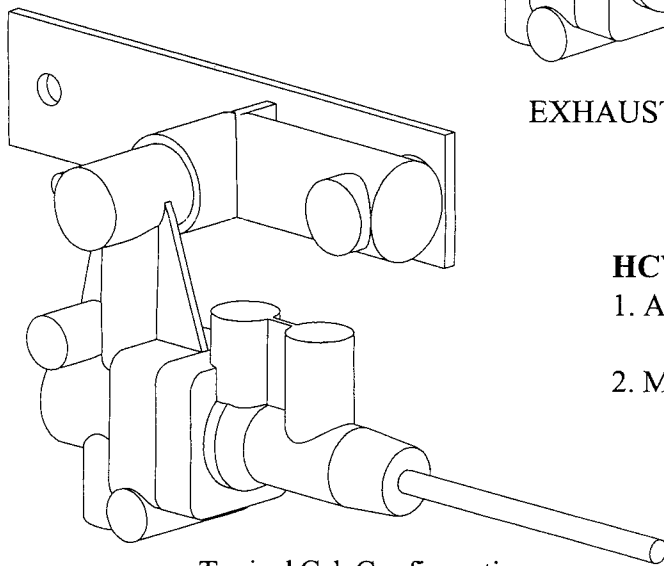
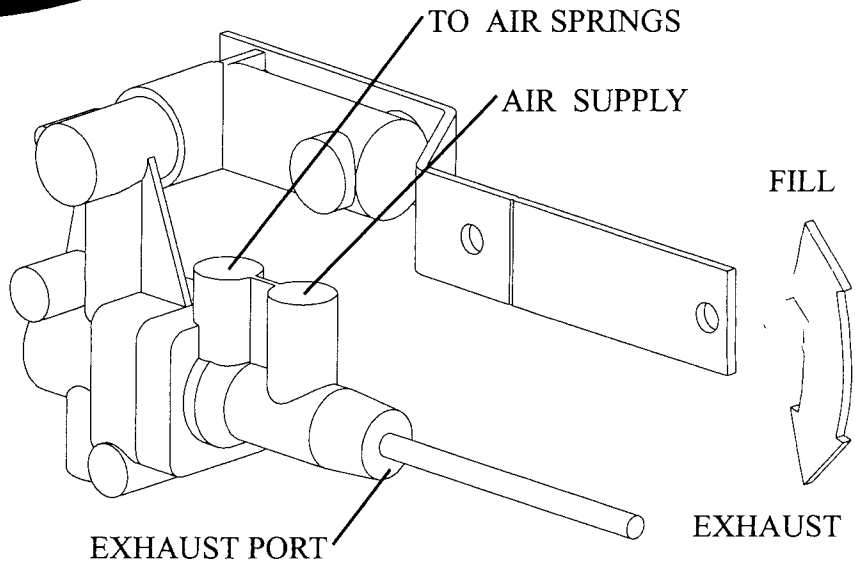

Typical Cab Configuration

HCV INSTALLATION NOTES:

1. At full up or down suspension travel:
MAXIMUM LEVER ANGLE IS 45°
2. Mount HCV parallel to frame rail

HCV INSTALLATION INSTRUCTIONS

Caution: Air lines are pressurized and may blow debris, USE EYE PROTECTION.

1. Disconnect and remove old valve.
2. Attach the Hadley H00450 HCV to the same mounting bracket. Or use the enclosed brackets as needed to mount the valve. NOTE: Always mount valve with the lever arm on the top side.
3. Attach the proper length lever to the H00450 HCV. Check for any interference or straight lining of the valve lever and linkage through the entire suspension travel.
4. Reconnect the air lines to the H00450 HCV per the picture above.
5. Adjust the ride height of the suspension utilizing the H00450 HCV lever and the vehicle manufacturer's ride height recommendations. Install centering pin to insure the valve dead band is at ride height.
6. Tighten all nuts to 60 to 80 in-lbs.
7. Remove centering pin.

PROBLEM	POSSIBLE CAUSE
Air springs flat	Obstruction in air line Insufficient air pressure to suspension Defective Pressure Protection Valve Defective HCV-see test procedure Air leak in system
Air springs raise to full height but do not exhaust	Obstructed air line Defective HCV-see test procedure
Air springs deflate when parked	Leak in air system-check with soapy water Defective HCV-see test procedure
Suspension will not maintain proper height	Obstructed air line Defective HCV-see test procedure
Hard ride	Ride height out of adjustment-readjust per vehicle service manual
Cab suspension overshoots center	Replace shocks Use short delay H00450 HCV

HCV TEST PROCEDURE

1. With a minimum of 90 psi at the supply port, rotate the lever up (as indicated on the side of the valve) 30° to 45° . Air should begin to flow into the air springs within seconds.
2. Rotate the lever to the neutral position. Air flow should stop.
3. Rotate the lever down 30° to 45° . Air should begin to exhaust from the air springs within seconds.
4. Rotate the lever to the neutral position. Air flow should stop.
5. If the valve fails to flow air or shut off as specified, replace with a new one.

REASONS TO REPLACE THE HCV

- HCV did not pass the test procedure
- Air leaks from the HCV
- HCV is damaged

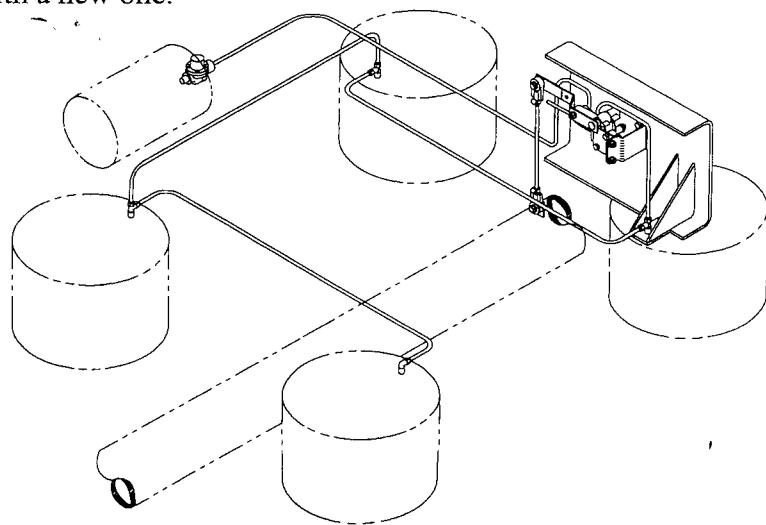

TYPICAL INSTALLATION

HADLEY PRODUCTS
2851 Prairie St SW
Grandville MI 49418
Telephone (616) 530-1717
Fax (616) 530-3283

Call or write regarding other
Hadley products: Cab or Chassis HCV's,
Air Horns, Mini Compressors, etc.