

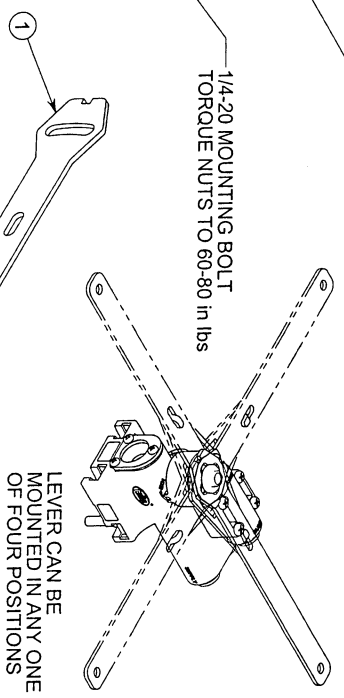

**H01502 SERIES
NEW GENERATION HEIGHT CONTROL VALVE
ZERO PRESSURE DUMP CONFIGURATION**

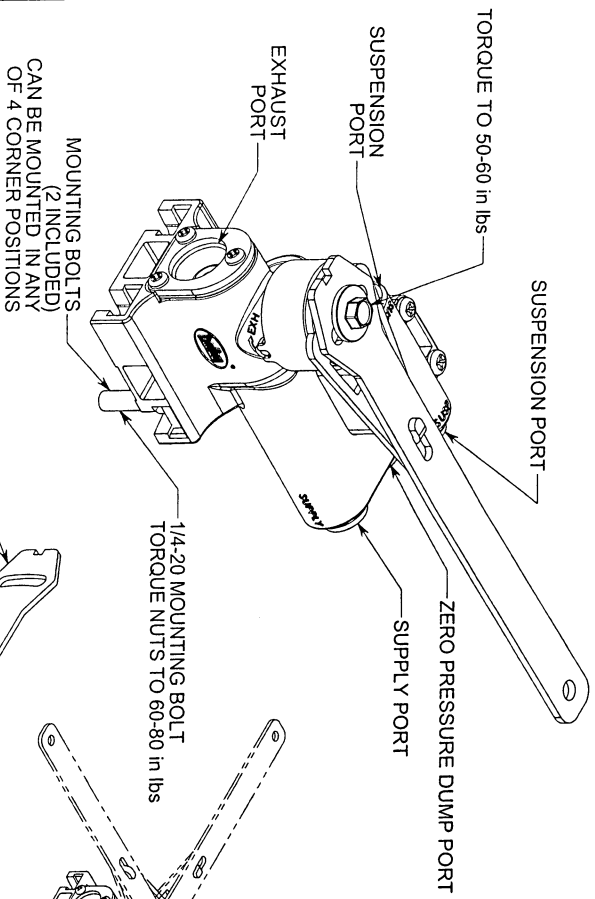

PARTS BAG		
ITEM NO	DESCRIPTION	QTY
1	8" ADJUSTABLE LEVER	1
2	7" ADJUSTABLE LEVER	1
3	7" STRAIGHT LEVER	1
4	3/8" PTC PLUG	1
5	MOUNTING BOLT	2
6	3/8" PTC 90° STEM FITTING	2
7	1/4-20 LOCK NUT	2
8	WASHER	2
9	INSTRUCTION SHEET	1

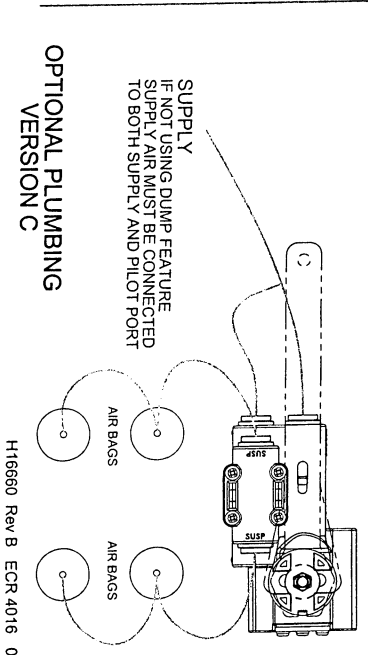
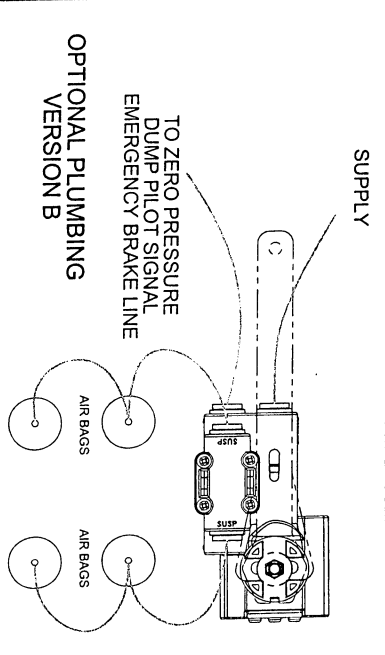
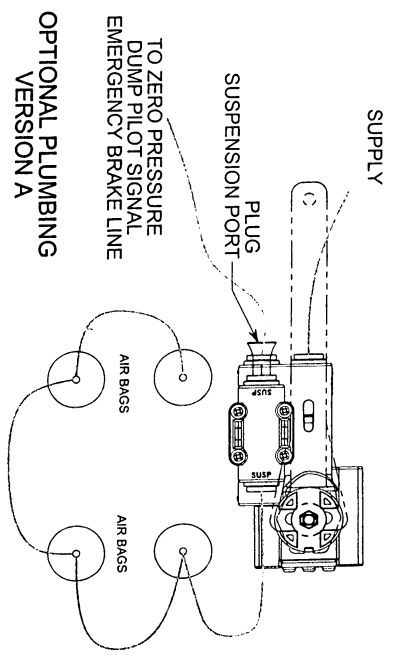
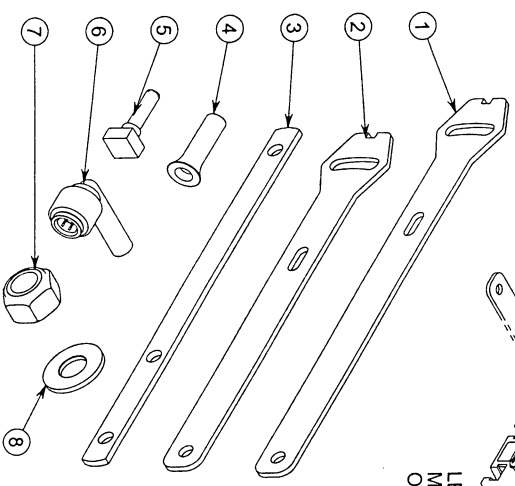



NEW GENERATION HEIGHT CONTROL VALVE ZERO PRESSURE DUMP CONFIGURATION INSTALLATION INSTRUCTIONS

- Determine mounting and valve orientation**
 - Hold NGHCV next to height control valve to be replaced and determine mounting orientation of the NGHCV for best hose routings.
 - NOTE: The supply port must be horizontal or pointing up.
 - Determine location of the 2 mounting studs and proper lever length.
 - Determine fill and exhaust orientation**
 - Each side of the NGHCV has arrows pointing toward the fill and exhaust directions.
 - Align the U-shaped cap detail with the fill/exhaust arrows that correspond with the fill and exhaust movements of the lever. Rotating the cap 180° will result in the opposite fill and exhaust lever movement.
- U" SHAPED CAP DETAIL

WHEN CAP DETAIL IS ON THIS SIDE OF VALVE, THE FILL / EXHAUST WILL BE IN THIS ORIENTATION

U" SHAPED CAP DETAIL

WHEN CAP DETAIL IS ON THIS SIDE OF VALVE, THE FILL / EXHAUST WILL BE IN THIS ORIENTATION
- Assemble NGHCV**
 - Install the correct lever onto the valve. The lever can be mounted in one of four directions.
 - Tighten screw to 50 - 60 in lbs.
 - Install mounting studs into the T-slots. Use a hammer to tap square head into the T-slot if needed.
 - Install NGHCV**
 - Remove old height control valve and note the hoses and ports.
 - Attach NGHCV to mounting bracket and tighten nuts to 60 - 80 in lbs.
 - Examine the end of each tube prior to insertion and trim the end as necessary to get a clean, 90° cut.
 - Attach hoses into the proper ports by pushing the tubes into the push-to-connect (PTC) fittings. Use the plug and 90° stem fitting included in this kit if necessary. **Make sure tubing does not interfere with lever rotation.**
 - NGHCV test procedure** - 90 psi minimum supply and pilot pressure
 - Rotate lever in the fill direction and fill air springs.
 - Rotate lever in the exhaust direction and exhaust air. Note: if fill and exhaust modes are backwards, exhaust air from suspension, loosen lever screw enough to separate lever from valve. Rotate lever 180°, reseat in cross pattern of valve and retighten lever screw. Rotate lever 180° to original position. Retest fill and exhaust modes.
 - Ride height adjustment**
 - Manually air up the valve to ride height. Check the vehicle manufacturer's ride height recommendations for correct height.
 - Reconnect linkage to end of lever.
 - Measure ride height.
 - Readjust ride height by loosening the lever screw enough to rotate the bottom to fill or exhaust the air until the correct ride height is attained.
 - Tighten the lever screw to 50 - 60 in lbs.
 - Double check the ride height measurement by dumping the suspension and allowing the NGHCV to air up to ride height (disconnect and reconnect the linkage).
 - Remeasure ride height and adjust if necessary.

HCV INSTALLATION NOTES

- OPTIMAL LEVER ANGLE FOR FULL UP OR DOWN TRAVEL IS BETWEEN 20° AND 45°
- MOUNT HCV WITH SUPPLY PORT HORIZONTAL OR POINTING UP
- IF NOT USING DUMP FEATURE, SUPPLY AIR MUST BE CONNECTED TO BOTH SUPPLY AND PILOT PORTS.

CAUTION - AIR LINES ARE PRESSURIZED AND MAY BLOW DEBRIS
- USE EYE PROTECTION

HCV TEST PROCEDURE

- With a minimum of 90 psi at the supply port, rotate the lever up (as indicated on the side of the valve) 30° to 45°. Air should flow into the air springs.
- Rotate the lever to the neutral position. Air flow should stop.
- Rotate the lever down 30° to 45°. Air should exhaust from the air springs.
- Rotate the lever to the neutral position. Air flow should stop.
- If valve fails to flow air or shut off as specified, replace with a new one.

REASONS TO REPLACE THE HCV

- HCV did not pass the test procedure
- Air leaks from the HCV
- HCV is damaged

TROUBLESHOOTING

PROBLEM	POSSIBLE CAUSE
Air springs flat	Obstructed air line Insufficient air pressure to suspension Defective Pressure Protection Valve Defective HCV (see test procedure) Air leak in system No pilot pressure
Air springs raise to full height but do not exhaust	Obstructed air line Supply line installed in suspension port Defective HCV (see test procedure)
Air springs deflate when parked	Leak in air system (check with soapy water) Defective HCV (see test procedure)
Suspension will not maintain proper height	Obstructed air line Ride height out of adjustment Defective HCV (see test procedure)
Hard ride	Ride height out of adjustment (readjust per vehicle service manual)
Ride height unequal side to side for (2) valve system	Reset ride height on each side (per installation instruction 6)